



■ **General Description**

OCP8120 is a PWM power LED driver IC. The switch current from few milliamps up to 1.6A. It allows high brightness power LED operating at high efficiency from 4V dc to 40V dc. Up to 200 KHz external controlled operation frequency. External resistor controlled the maximum output current to single LED or a LED string.

■ **Features**

- Only 5 external components required
- Output switch current up to 1.6A
- 4V~40V wide operation voltage range
- High efficiency
- ESD protection HBM 2KV
- TO252-5L pin power packages

■ **Application**

- DC/DC LED driver
- Automotive
- Lighting

■ **Pin Configuration**

(Top View)

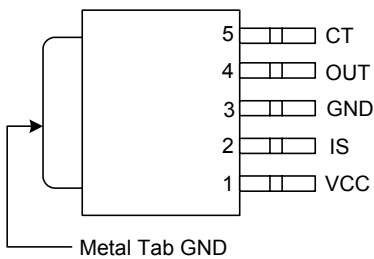

Pin Number	Pin Name	Pin Function
1	VCC	Input voltage 4V~40V
2	IS	Peak current sense pin
3	GND	Ground
4	OUT	Driver output pin
5	CT	Oscillator timing capacitor

■ **Block Diagram**

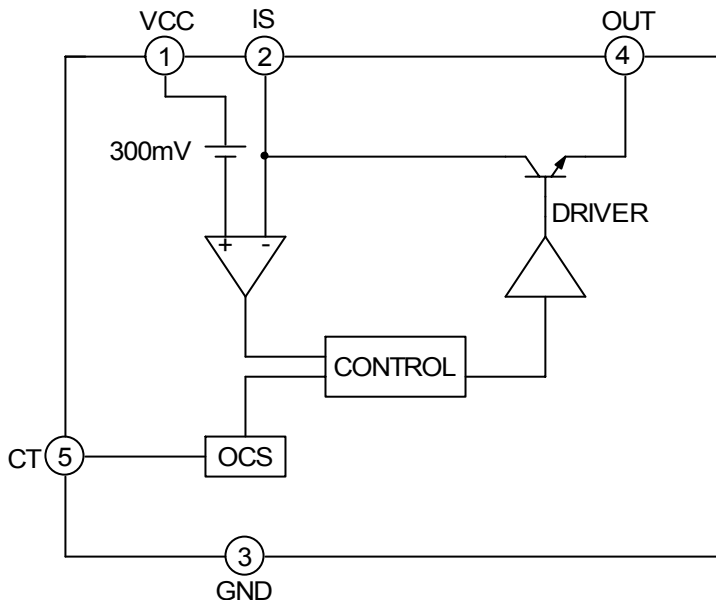



ORIENT-CHIP

### Absolute Maximum Ratings

Input Voltage, VCC	-0.3V to 40V
Output Voltage, OUT	-0.3V to 40V
Maximum Junction Temperature, T <sub>J</sub>	150°C
Storage Temperature Range	-40°C to 150°C
Lead Temperature (soldering, 10 sec.)	260°C

Note: Exceeding these ratings could cause damage to the device. All voltages are with respect to Ground. Currents are positive into, negative out of the specified terminal.

### Electrical Characteristics (VCC=5V, Ta=25°C, Unless otherwise noted)

Parameter	Symbol	Condition	Min.	Typ.	Max.	Unit	Apply Pin
Supply Current	I <sub>CC</sub>	VCC=4~40V			4	mA	VCC
Output Drop-out Voltage	V <sub>DP</sub>	I <sub>OUT</sub> =1A, V <sub>IS</sub> -V <sub>OUT</sub>		1	1.3	V	OUT
Output Leakage Current	I <sub>LK</sub>	V <sub>IS</sub> -V <sub>OUT</sub> =40V		0.01	10	μA	
Current Sense Voltage	V <sub>CS</sub>	VCC-V <sub>IS</sub>	270	300	330	mV	IS
Maximum duty cycle	T <sub>DC</sub>	V <sub>IS</sub> =VCC		85		%	CT
CT Charge Current	I <sub>CH</sub>			35		μA	

### Power Dissipation Table

Package	θ <sub>JA</sub> (°C/W)	Derating factor (mW/°C) T <sub>A</sub> ≥25°C	Power rating (mW) T <sub>A</sub> ≤25°C	Power rating (mW) T <sub>A</sub> =70°C	Power rating (mW) T <sub>A</sub> =85°C
TO252-5L	80	12.5	1560	1000	812

Note: Junction Temperature Calculation: T<sub>J</sub>=T<sub>A</sub>+(P<sub>D</sub>×θ<sub>JA</sub>).

P<sub>D</sub>: Power Dissipation, T<sub>A</sub>: Ambient temperature, θ<sub>JA</sub>: Thermal Resistance-Junction to Ambient

The θ<sub>JA</sub> numbers are guidelines for the thermal performance of the device/PC-board system.

All of the above assume no ambient airflow.

### Recommended Operating Conditions

Parameter	Symbol	Min.	Typ.	Max.	Unit
Supply Voltage	VCC	4		40	V
Output Switch Current	I <sub>out</sub>			1.6	A
Operating free-air temperature range	T <sub>a</sub>	-40		85	°C

### Typical Application Circuit

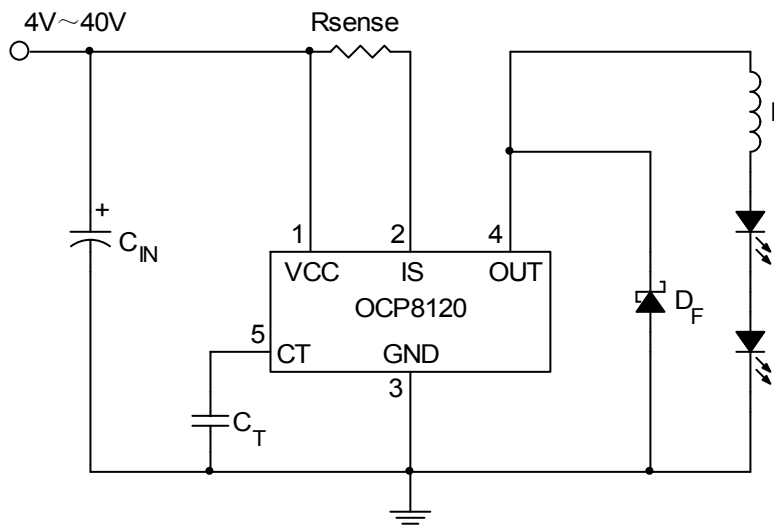

Fig.1



## ■ Application Information

### Low Voltage DC/DC Application

The OCP8120 was designed for power LED driving application. Only 5 external components were required for low voltage application. Fig.1 shows the typical application circuit for input voltage from 4V to 40V. Buck power conversion topology was used and total forward voltage (at expecting current) of the LED string should lower than supply voltage by 1.6V at least.

### Input Bypass Capacitor

The input by-pass capacitor  $C_{IN}$  holds the input voltage and filters out the switching noise of OCP8120.

### Flywheel Diode

The fast recovery diode was recommended for flywheel diode  $D_F$ . This is because the high reverse recovery current will cause the voltage drop across  $R_{sense}$  being higher than 300mV, and consequently the switch will be turned off which has just been turned on.

### LED Driving Current

The peak current  $I_{PK}$  flow through LEDs was decided by:

$$I_{PK} = \frac{300mV}{R_{sense}}$$

The average current on LEDs was determined by the peak –to- peak ripple current that was decided by inductor L. Assume the target average current 550mA on LEDs and ripple current 100mA then the  $R_{sense}$  should be:

$$R_{sense} = \frac{300mV}{550mA + 0.5 \cdot 100mA} = 0.5\Omega$$

The  $R_{sense}$  value should higher than 200m $\Omega$  so that switch current won't over the recommended maximum switch current 1.6A.

### Inductor

The Inductor L stores energy during switch turn-on period and discharge driving current to LEDs via flywheel diode while switch turn-off. In order to reduce the current ripple on LEDs, the L value should high enough to keep the system working at continuous-conduction mode that inductor current won't fall to zero.

Since in steady-state operation the waveform must repeat from one time period to the next, the internal of the inductor voltage  $v_L$  over one time period must be zero:

$$\int_0^{T_s} v_L dt = \int_0^{t_{ON}} v_L dt + \int_{t_{ON}}^{T_s} v_L dt = 0 \quad \text{Where } T_s = t_{ON} + t_{OFF}$$

Therefore

$$\frac{t_{ON}}{t_{OFF}} = \frac{V_{LED} + V_F}{V_{CC} - V_{R_{sense}} - V_{SAT} - V_{LED}}$$

Where,  $V_{LED}$  is the total forward voltage (at expecting current) of the LED string,  $V_F$  is the forward voltage of the flywheel diode  $D_F$ ,  $V_{R_{sense}}$  is the peak value of the voltage drop across  $R_{sense}$  which is 300mV, and  $V_{SAT}$  is the saturation voltage of the switch which has a typical value of 1V.

Since the operation frequency  $f$  is determined by choosing appropriate value for timing capacitor  $C_T$ , the switch turn-on time can also be known by

$$t_{ON} = D \cdot T_s = \frac{D}{f} \quad \text{Where } D(\text{Dutycycle}) = \frac{t_{ON}}{t_{ON} + t_{OFF}}$$

With knowledge of the peak switch current and switch on time, the value of inductance can be calculated.

$$L = \frac{V_{CC} - V_{R_{sense}} - V_{SAT} - V_{LED}}{I_{PK}} \cdot t_{ON}$$



■ Ordering Information

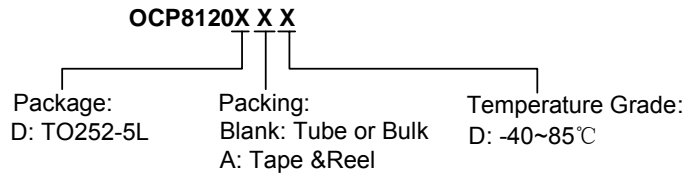

■ Marking Information

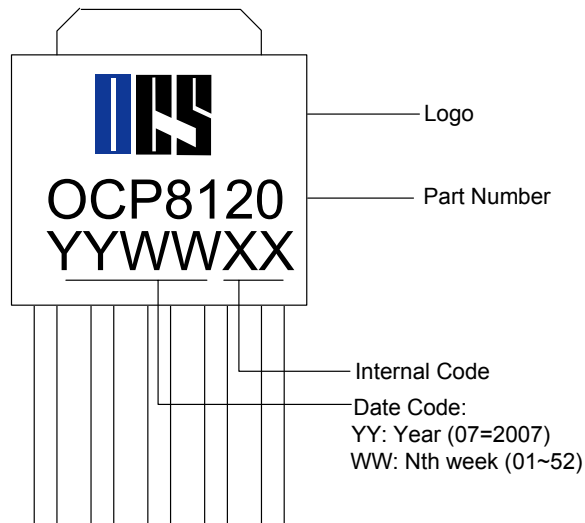



■ Package Information

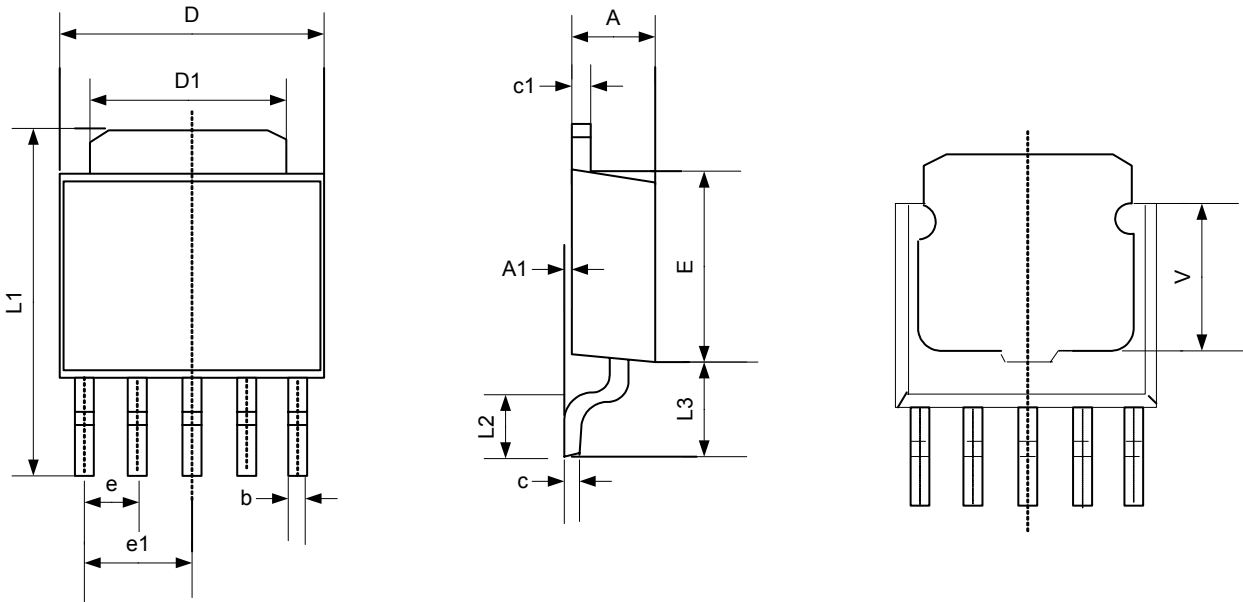

Symbol	Dimensions In Millimeters		Dimensions In Inches	
	Min.	Max.	Min.	Max.
A	2.200	2.400	0.087	0.094
A1	0.000	0.127	0.000	0.005
b	0.400	0.600	0.016	0.024
c	0.430	0.580	0.017	0.023
c1	0.430	0.580	0.017	0.023
D	6.350	6.650	0.250	0.262
D1	5.200	5.400	0.205	0.213
E	5.400	5.700	0.213	0.224
e	1.270TYP.		0.050TYP.	
e1	2.540TYP.		1.000TYP.	
L1	9.500	9.900	0.374	0.390
L2	1.400	1.780	0.055	0.070
L3	2.550	2.900	0.100	0.114
V	3.800REF		0.150REF	



■ Packing Information

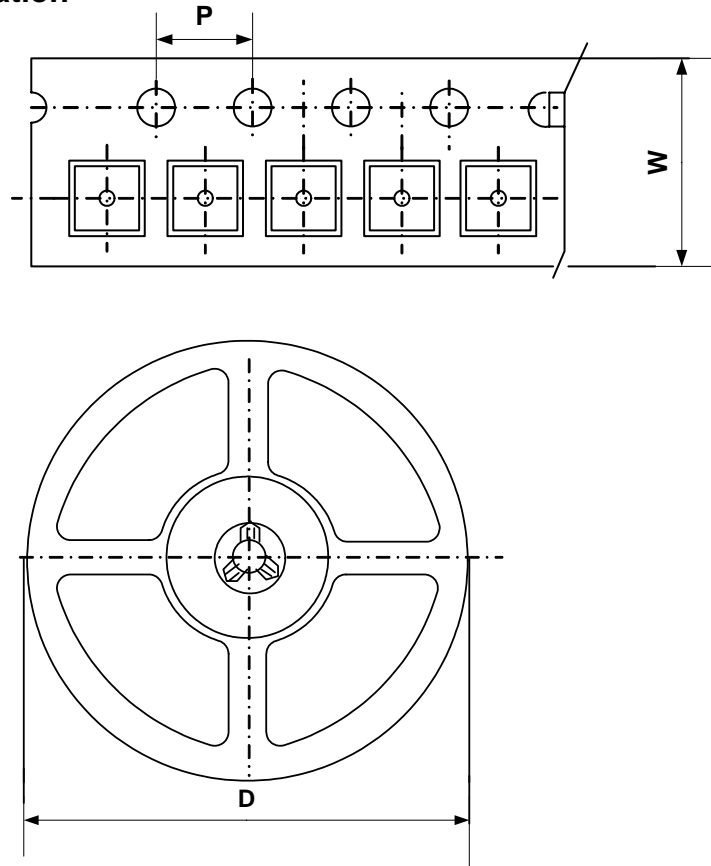

Package Type	Carrier Width (W)	Pitch (P)	Reel Size(D)	Packing Minimum
TO252	16.0±0.1 mm	4.0±0.1 mm	330±1 mm	2500pcs

Note: Carrier Tape Dimension, Reel Size and Packing Minimum