



Preliminary

OCP9200

Current Limited Load Switch in SOT-23 Package

ORIENT-CHIP

### General Description

The OCP9200 SmartSwitch is a member of Orient-chip's Application Specific Power MOSFET product family. It is a Current Limited P-channel MOSFET power switch designed for high-side load-switching applications. This switch operates with inputs ranging from 2.7V to 5.5V, making it ideal for both 3V and 5V systems. An integrated current-limiting circuit protects the input supply against large currents which may cause the supply to fall out of regulation. The OCP9200 is also protected from thermal overload which limits power dissipation and junction temperatures. It can be used to control loads that require up to 1 A. Current limit threshold is programmed with a resistor from SET to ground. The quiescent supply current is typically a low 15  $\mu$  A max. In shutdown mode, the supply current decreases to less than 1  $\mu$  A.

The OCP9200 is available in a 5 pin SOT-23 specified over -40 to 85°C.

### Features

- 2.7V to 5.5V Input voltage range
- Programmable over current threshold
- Fast transient response:
- <1  $\mu$  s response to short circuit
- Low quiescent current
  - 15  $\mu$  A typical
  - 1  $\mu$  A max with Switch off
- 160m $\Omega$  typical RDS(ON)
- Only 2.5V needed for ON/OFF Control
- Undervoltage Lockout
- Thermal shutdown
- Temp range -40 to 85°C
- 4kV ESD Rating
- 5 pin SOT-23 package

### Applications

- Peripheral ports
- Notebook computers
- Personal communication devices
- Hot swap supplies

### Pin Configuration

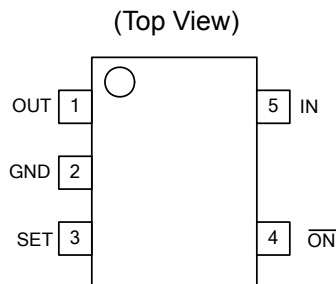

QFN Pin No.	Pin Name	Pin Function
1	OUT	P-channel MOSFET drain. Connect 0.47 $\mu$ F capacitor from OUT to GND.
2	GND	Ground connection
3	SET	Current-Limit Set Input. A resistor from SET to ground sets the current limit for the switch.
4	$\overline{\text{ON}}$	Enable Input. Two versions are available, active-high and active-low. See ordering information for details.
5	IN	P-channel MOSFET source. Connect 1 $\mu$ F capacitor from IN to GND.

### Block Diagram

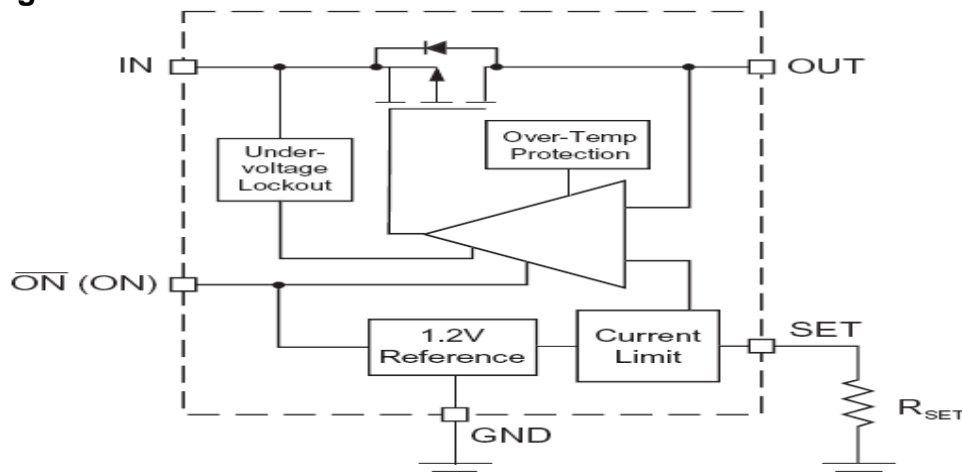



Preliminary

OCP9200

Current Limited Load Switch in SOT-23 Package

ORIENT-CHIP

### Typical Application

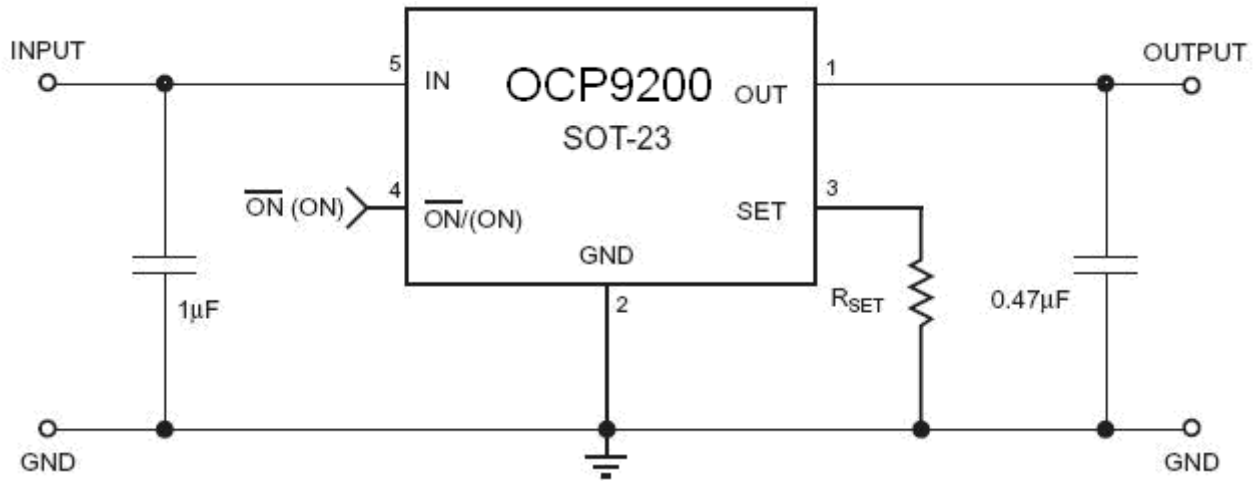

### Absolute Maximum Ratings ( $T_A = 25^\circ\text{C}$ unless otherwise noted)

Parameter	Symbol	Value	Unit
IN to GND	$V_{IN}$	-0.3 to 6	V
ON(OFF) to GND	$V_{ON}$	-0.3 to $V_{IN}+0.3$	V
SET, OUT to GND	$V_{SET}, V_{OUT}$	-0.3 to $V_{IN}+0.3$	V
Maximum Continuous Switch Current	$I_{MAX}$	2	A
Operating Junction Temperature Range	$T_J$	-40 to 150	$^\circ\text{C}$
Maximum Soldering Temperature (at Leads)	$T_{LEAD}$	300	$^\circ\text{C}$
ESD Rating <sup>1</sup> - HBM	$V_{ESD}$	4000	V

Note: Stresses above those listed in Absolute Maximum Ratings may cause permanent damage to the device. Functional operation at conditions other than the operating conditions specified is not implied. Only one Absolute Maximum rating should be applied at any one time.

Note 1: Human body model is a 100pF capacitor discharged through a 1.5kΩ resistor into each pin.

### Thermal Characteristics

Symbol	Parameter	Value	Units (Limits)
$\theta_{JA}$	Thermal Resistance <sup>2</sup>	150	$^\circ\text{C}/\text{W}$
$P_D$	Power Dissipation <sup>2</sup>	667	mW

Note 2 : Mounted on a demo board .



Preliminary

OCP9200

Current Limited Load Switch in SOT-23 Package

ORIENT-CHIP

■ Electrical Characteristics

( $V_{IN}=5V, T_A=-40$  to  $85^{\circ}C$  unless otherwise noted. Typical values are at  $T_A=25^{\circ}C$  )

SYMBOL	ITEMS	CONDITIONS	Min.	Typ.	Max.	UNIT
$V_{IN}$	Operation Voltage		2.7		5.5	V
$I_Q$	Quiescent Current	$V_{IN} = 5V, ON (ON) = active, I_{OUT} = 0$		15	30	$\mu A$
$I_{Q(OFF)}$	Off Supply Current	ON (ON) = inactive, $V_{IN} = 5.5V$			1	$\mu A$
$I_{SD(OFF)}$	Off Switch Current	ON (ON) = inactive, $V_{IN} = 5.5V, V_{OUT} = 0$		0.03	15	$\mu A$
$V_{UVLO}$	Undervoltage Lockout	Rising edge, 1% hysteresis,	2.0	2.3	2.7	V
$R_{DS(ON)}$	On-Resistance	$V_{IN}=5.0V$		160	180	m $\Omega$
		$V_{IN}=4.5V$		165		m $\Omega$
		$V_{IN}=3.0V$		195	230	m $\Omega$
$I_{LIM}$	Current Limit	$R_{SET} = 6.8k\Omega$	0.75	1	1.25	A
$I_{LIM(MIN)}$	Minimum Current Limit			150		mA
$V_{ON(L)}$	ON (ON) Input Low Voltage				0.8	V
$V_{ON(H)}$	ON (ON) Input High Voltage	$V_{IN}=2.7V$ to $3.6V$	2.0			V
		$V_{IN}=4.5V$ to $5.5V$	2.4			V
$I_{ON(SINK)}$	ON (ON) Input leakage	$V_{ON} = 5.5V$		0.01	1	$\mu A$
$T_{RESP}$	Current Limit Response Time	$V_{IN}=5V$		0.8		$\mu s$
$T_{OFF}$	Turn-Off Time	$V_{IN}=5V, R_L=10\Omega$		0.4	2	$\mu s$
$T_{ON}$	Turn-On Time	$V_{IN}=5V, R_L=10\Omega$		40	200	$\mu s$

■ Typical Performance Characteristics (Unless otherwise noted,  $V_{IN}=5V, T_A=25^{\circ}C$ )

Quiescent Current vs. Temperature

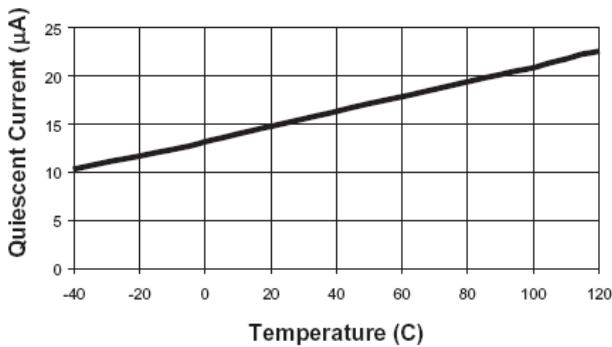

Quiescent Current

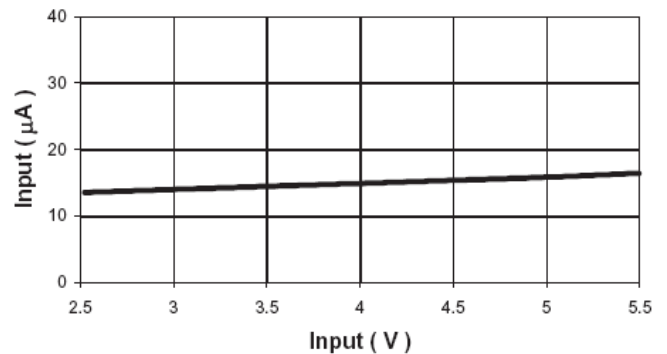

Output Current vs  $V_{OUT}$

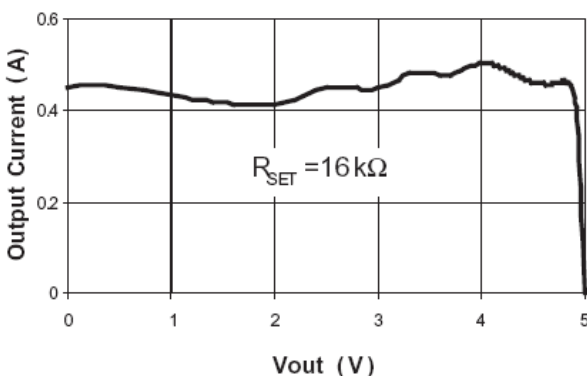

$R_{DS(ON)}$  VS. Temperature

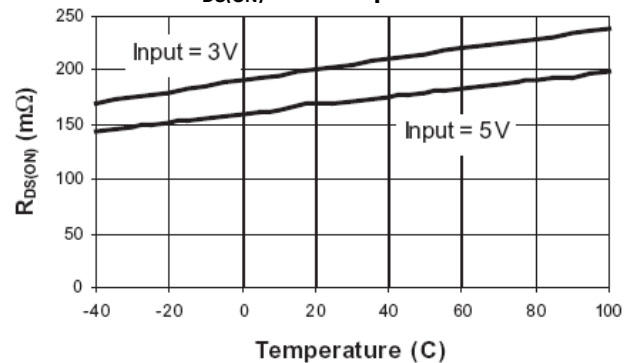



Preliminary

OCP9200

Current Limited Load Switch in SOT-23 Package

ORIENT-CHIP

■ Typical Performance Characteristics (Unless otherwise noted,  $V_{IN}=5V, T_A=25^\circ C$ ) (cont.)

Off-Supply Current vs. Temperature

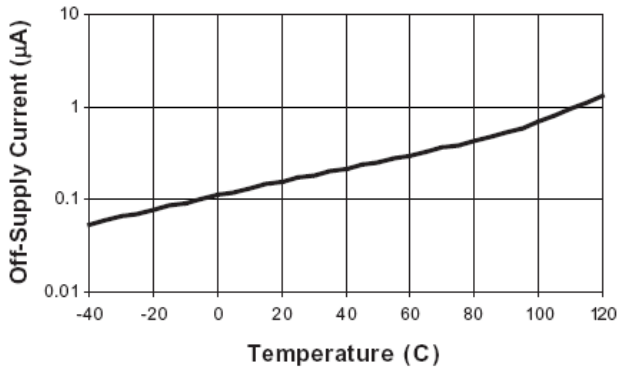

Off-Switch Current vs. Temperature

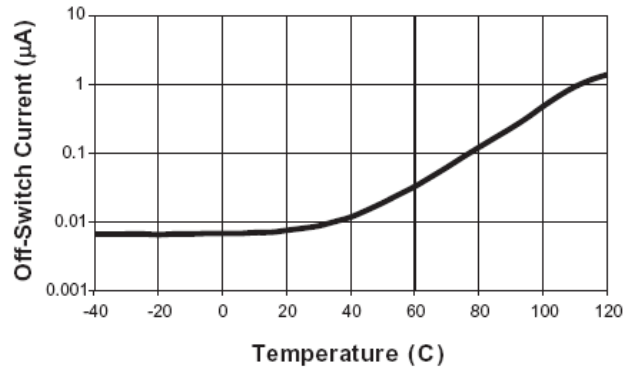

Turn-ON vs. Temperature

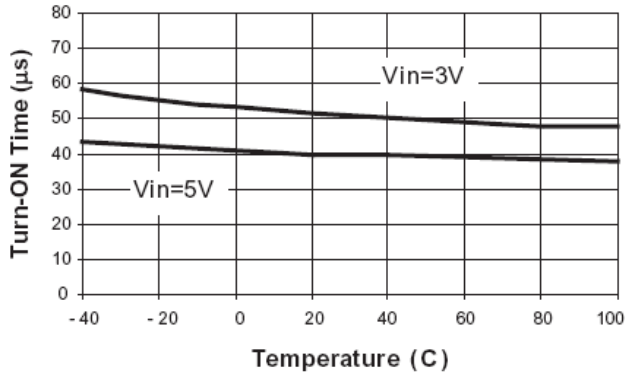

Turn-OFF vs. Temperature

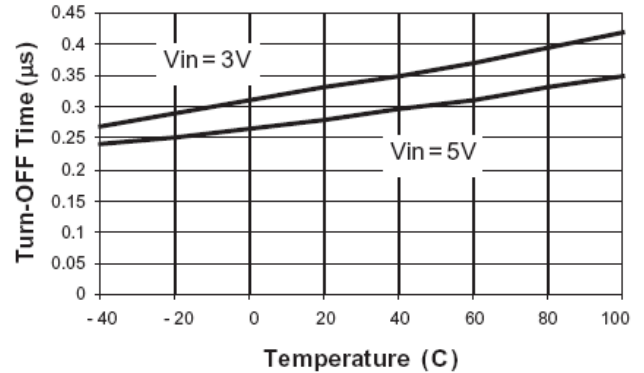

Turn - On  
 $R_L=10\Omega, C_L=0.47\mu F$

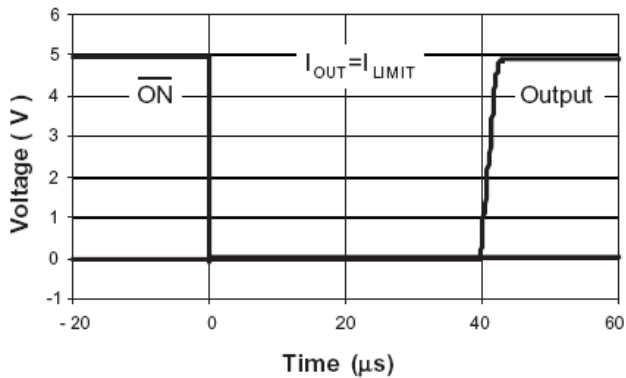

Turn - Off  
 $R_L=10\Omega$

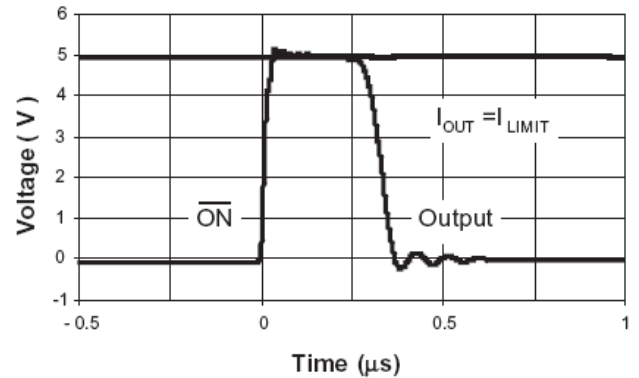



Preliminary

OCP9200

Current Limited Load Switch in SOT-23 Package

ORIENT-CHIP

■ Typical Performance Characteristics (Unless otherwise noted,  $V_{IN}=5V, T_A=25^\circ C$ ) (cont.)

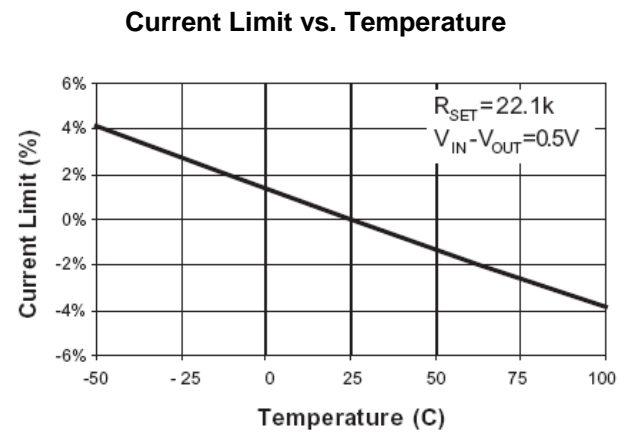
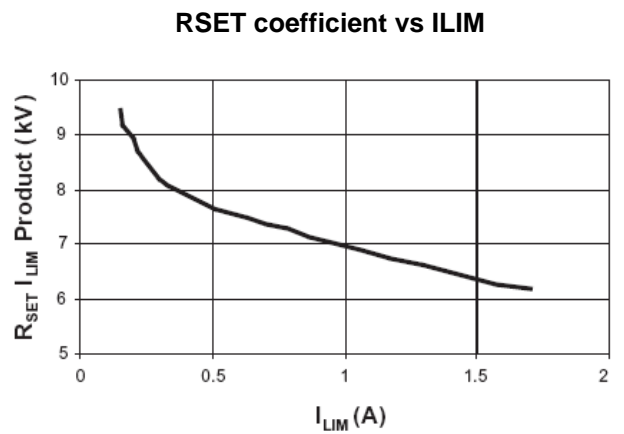
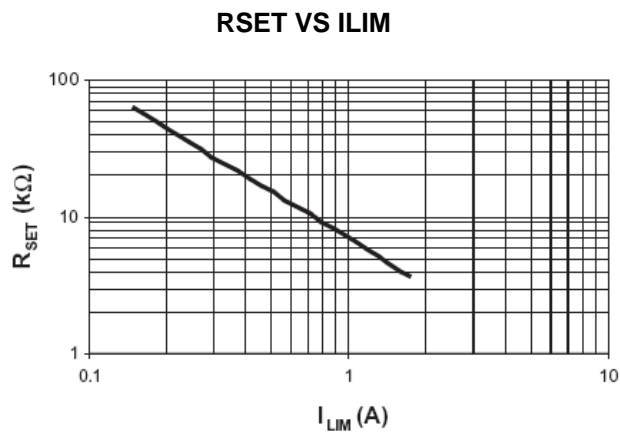
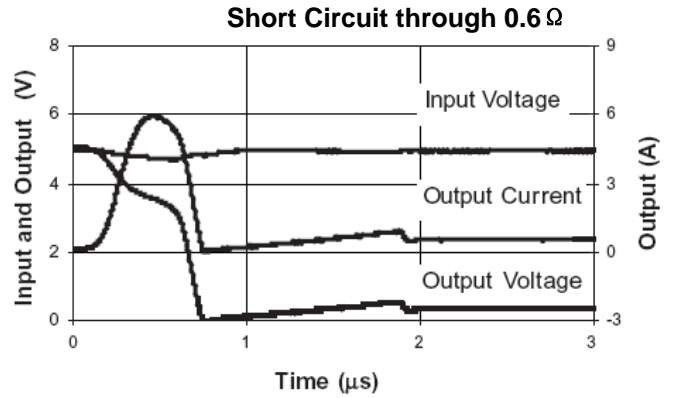
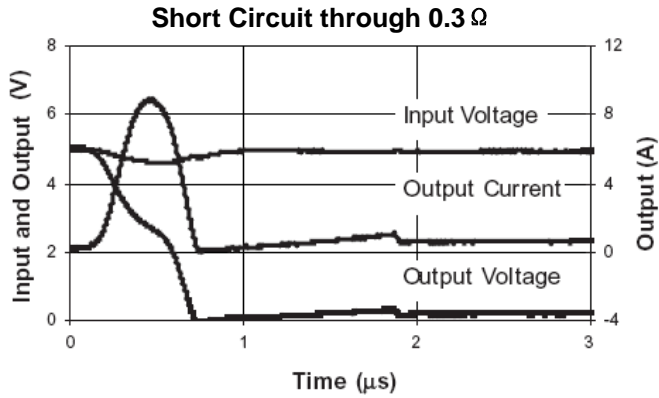



Preliminary

OCP9200

Current Limited Load Switch in SOT-23 Package

ORIENT-CHIP

### Application Information

#### Setting Current Limit

In most applications, the variation in ILIM must be taken into account when determining RSET. The ILIM variation is due to processing variations from part to part, as well as variations in the voltages at IN (pin 5) and OUT (pin 3), plus the operating temperature. See charts "Current Limit vs. Temperature", and "Output Current vs. VOUT". Together these three factors add up to a ±25% tolerance (see ILIM specification in Electrical Characteristics section). In the figure below, a cold device with a statistically higher current limit, and a hot device with a statistically lower current limit, both with RSET equal to 10.5kΩ are shown. While the chart, "RSET vs. ILIM" indicates an ILIM of 0.7A with an RSET of 10.5kΩ, this figure shows that the actual current limit will be at least 0.525A, and no greater than 0.880A.

Current Limit Using 10.5 kΩ

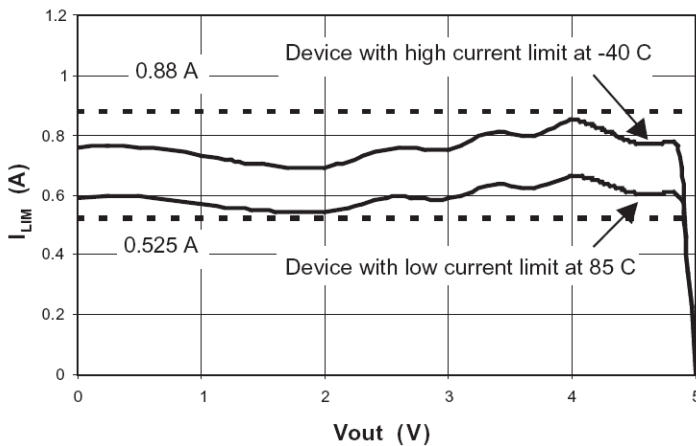

To determine RSET, start with the maximum current drawn by the load, and multiply it by 1.33. (typical\_ILIM = minimum\_ILIM / 0.75) This is the typical current limit value. Next, refer to "RSET vs. ILIM" and find the RSET that corresponds to the typical current limit value. Choose the largest resistor available that is less than or equal to it. For greater precision, the value of RSET may also be calculated using the ILIM RSET product found in the chart "RSET coefficient vs. ILIM". The maximum current is derived by multiplying the typical current for the chosen RSET in the chart by 1.25. A few standard resistor values are listed in the table "Current Limit RSET Values".

Current Limit RSET Values

R <sub>SET</sub> (kΩ)	Current Limit typ (mA)	Device will not current limit below: (mA)	Device always current limits below: (mA)
40.2	200	150	250
30.9	250	188	313
24.9	300	225	375
22.1	350	263	438
19.6	400	300	500
17.8	450	338	563
16.2	500	375	625
14.7	550	413	688
13.0	600	450	750
10.5	700	525	875
8.87	800	600	1000
7.50	900	675	1125
6.81	1000	750	1250
6.04	1100	825	1375
5.49	1200	900	1500
4.99	1300	975	1625
4.64	1400	1050	1750

Example: A USB port requires 0.5A. 0.5A multiplied by 1.33 is 0.665A. From the chart named "RSET vs. ILIM", RSET should be less than 11kΩ. 10.5 kΩ is a standard value that is a little less than 11kΩ but very close. The chart reads approximately 0.700A as a typical ILIM value for 10.5kΩ. Multiplying 0.700A by 0.75 and 1.25 shows that the OCP9200 will limit the load current to greater than 0.525A but less than 0.875A.



Preliminary

OCP9200

Current Limited Load Switch in SOT-23 Package

ORIENT-CHIP

### Application Information(cont.)

#### Overload Operation

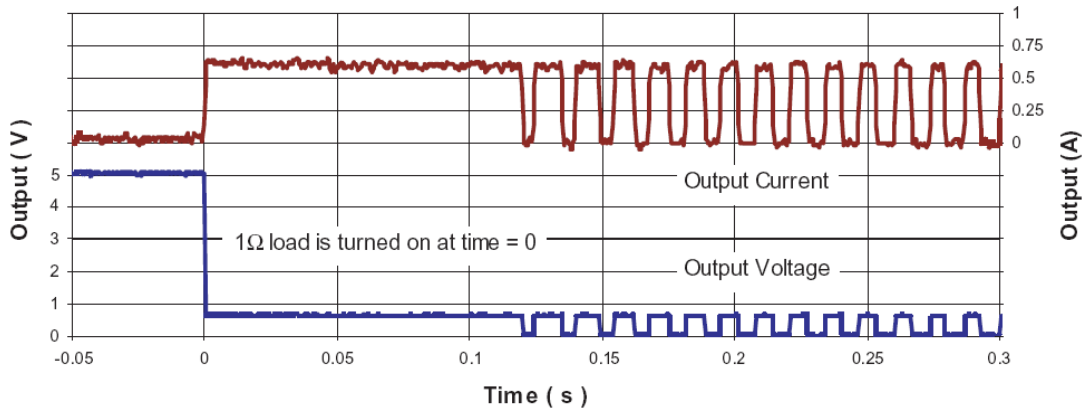

#### Operation in Current Limit

When a heavy load is applied to the output of the OCP9200, the load current is limited to the value of  $I_{LIM}$  determined by RSET. See the figure "Overload Operation". Since the load is demanding more current than  $I_{LIM}$ , the voltage at the output drops. This causes the OCP9200 to dissipate a larger than normal quantity of power, and its die temperature to increase. When the die temperature exceeds an over temperature limit, the OCP9200 will shut down until it has cooled sufficiently, at which point it will startup again. The OCP9200 will continue to cycle on and off until the load is removed, power is removed, or until a logic high level is applied to ON (pin 4).

#### Enable Input

In many systems, power planes are controlled by integrated circuits which run at lower voltages than the power plane itself. The enable input ON (pin 4) of the OCP9200 has low and high threshold voltages that accommodate this condition. The threshold voltages are compatible with 5 volt TTL, and 2.5 volt to 5 volt CMOS.

#### Reverse Voltage

The OCP9200 is designed to control current flowing from IN to OUT. If a voltage is applied to OUT which is greater than the voltage on IN, large currents may flow. This could cause damage to the OCP9200.

### Ordering Information

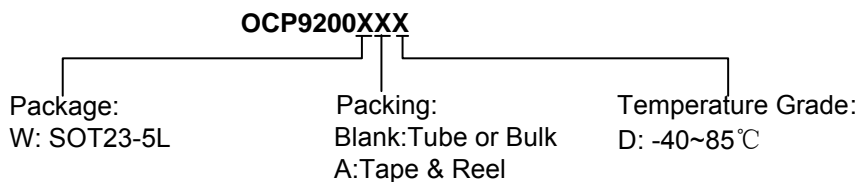

### Marking Information

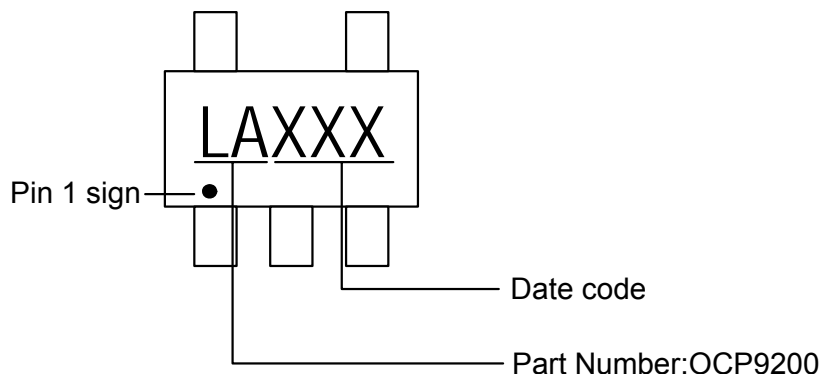



Preliminary

OCP9200

Current Limited Load Switch in SOT-23 Package

ORIENT-CHIP

Package Information

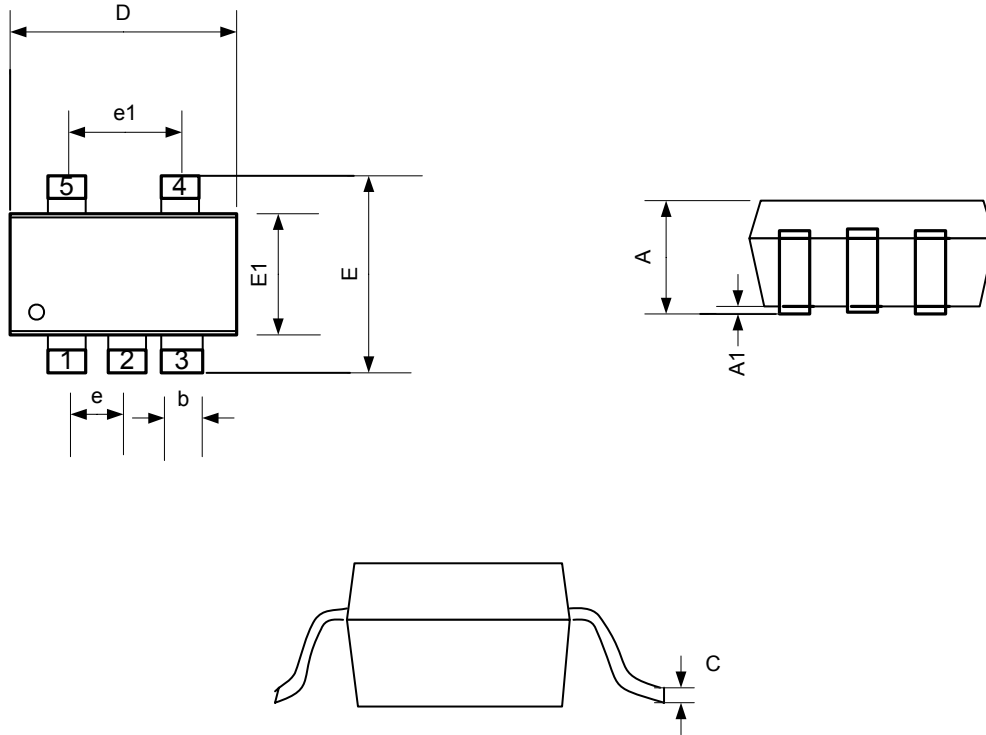

Symbol	Dimensions In Millimeters		Dimensions In Inches	
	Min.	Max.	Min.	Max.
A	0.90	1.30	0.036	0.051
A1		0.15		0.006
b	0.35	0.50	0.014	0.020
C	0.09	0.20	0.0036	0.008
D	2.80	3.05	0.112	0.120
E	2.60	3.00	0.102	0.118
E1	1.50	1.75	0.060	0.070
e	0.95 Bsc.		0.038 Bsc.	
e1	1.90 Bsc.		0.076 Bsc.	



Preliminary

OCP9200

Current Limited Load Switch in SOT-23 Package

ORIENT-CHIP

■ Packing Information

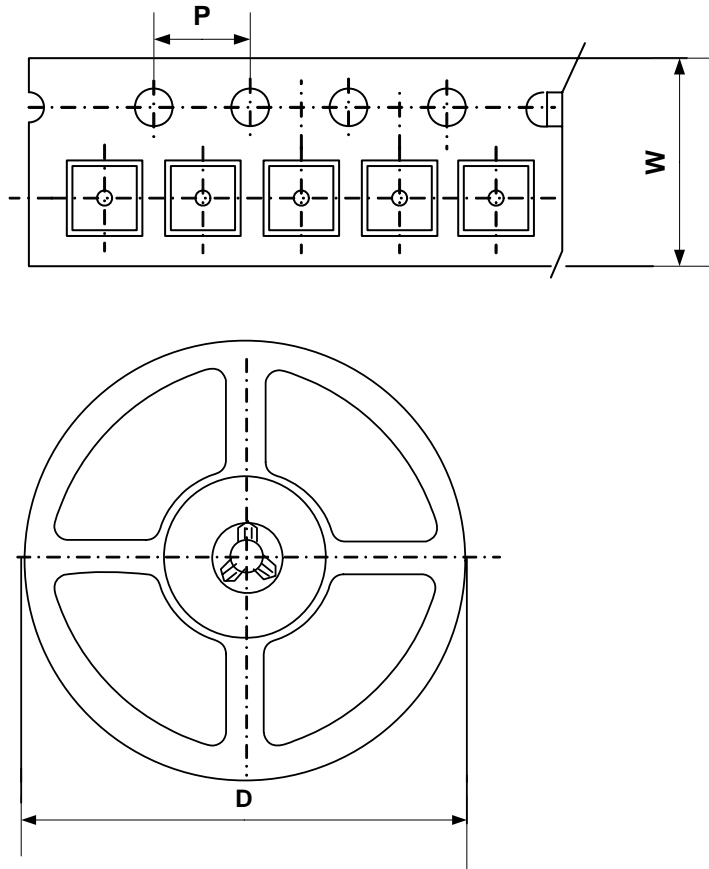

Package Type	Carrier Width (W)	Pitch (P)	Reel Size(D)	Packing Minimum
SOT23-5L	8.0±0.1 mm	4.0±0.1 mm	180±1 mm	3000pcs

Note: Carrier Tape Dimension, Reel Size and Packing Minimum